

**FIX IT UP...STRAP IT DOWN**

# **THE SAFE ROOF RETROFIT**



**A SAFER ROOF  
A SAFER YOU**

**BOOKLET**

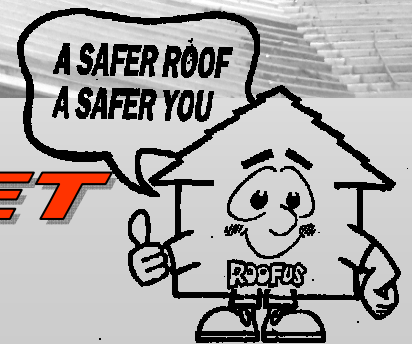

Produced by the Construction Resource & Development Centre.



Reprinted by the Construction Industry Council

Over the past 15 years the frequency and intensity of hurricanes impacting Jamaica has increased significantly. Roofs constructed with timber frame are more vulnerable to hurricane force winds and prior to hurricane Gilbert many of the houses constructed did not use roofs connectors that would hold the roof together in the event of a hurricane. Hurricane straps, collar ties, hold down bolts and accurate details at the edge of the roof are some of the techniques that can be used to secure roofs.

This booklet was produced to assist builders and homeowners to strengthen roofs against hurricane damage.

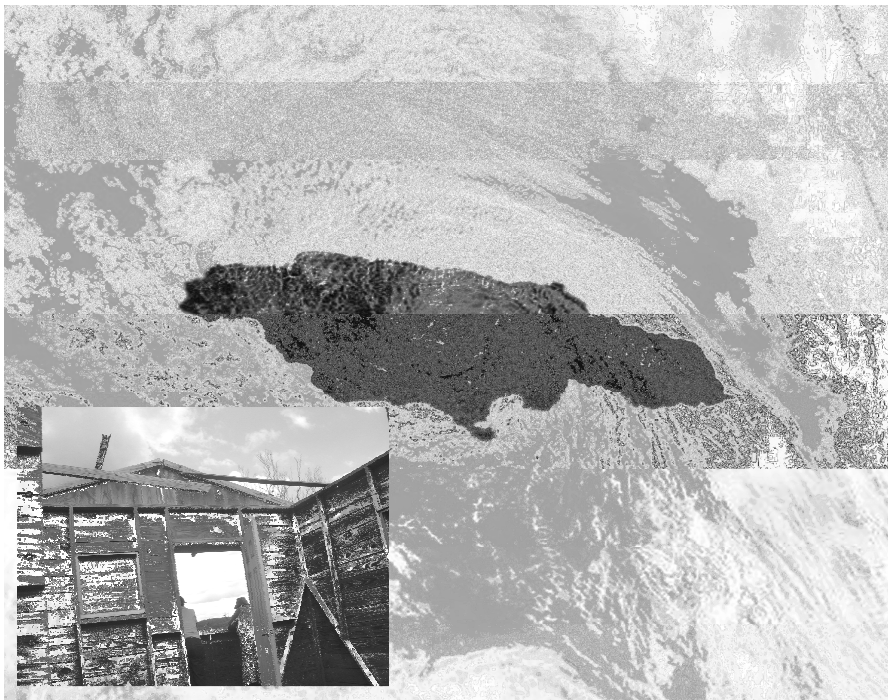

First printed in 1989  
Reprinted 2008

All rights reserved © 2008  
Construction Resource & Development Centre



The Construction Resource & Development Centre is a not for profit organization founded in 1983. The Centre aims to improve the standards of housing for the people in Jamaica and the Caribbean. It aims to do so primarily through research and information dissemination and hands on demonstrations placing specific emphasis on vulnerable groups.

The CRDC has worked in several communities training individuals and groups on methods to make their homes and communities disaster resilient.

Produced by the Construction Resource & Development Centre  
11 Lady Musgrave Avenue  
Kingston 5

Tel: 1 (876) 978 4061  
Email: [crdc@cwjamaica.com](mailto:crdc@cwjamaica.com)

Fax: 1 (876) 978 1249



The Construction Industry Council (CIC) is the umbrella organization for the Jamaican Construction Industry. The Council has been operating for 49 years and it represents interest of persons working within the Construction Industry.

The membership of the CIC consist of five professional associations:

- Incorporated Masterbuilders Association of Jamaica (IMAJ)
- Jamaica Institution of Engineers (JIE)
- Jamaican Institute of Quantity Surveyors (JIQS)
- Jamaican Institute of Architects (JIA)
- Land Surveyors Association of Jamaica.

## INTRODUCTION

### Understanding Your Roof

Roofs are held together by five major connections and improper installation of any of these connections will result in partial damage or complete loss of the roof.

These connections are between the

- **Wallplate and the walls**
- **Rafters and the wall-plate**
- **Ridgeboard and the rafters**
- **Roof sheets or shingles and the laths**

In addition to these five areas, the details at the eaves and gable ends of the roof are also very important.

Most of the damage to roofs during hurricanes occur because one or all of these components fail. After the Hurricanes, most of the roofs were not properly replaced and many of them will fail again.

This book is intended as a guide to persons who want to strengthen their roof against hurricane damage. It will focus specifically on roofs and will identify the main causes of roof damage. In addition it will help the householders to understand how the damage occurs and what preventative measures they can take, with the help of a contractor or carpenter, to minimize the damage.

The cost of upgrading and strengthening a roof is a fraction of the cost of replacing the entire roof when damaged by a hurricane. This book examines the critical areas you need to check on your roof and it provides technical information to fix it up and strap it down!

Let us now examine the roof connections.

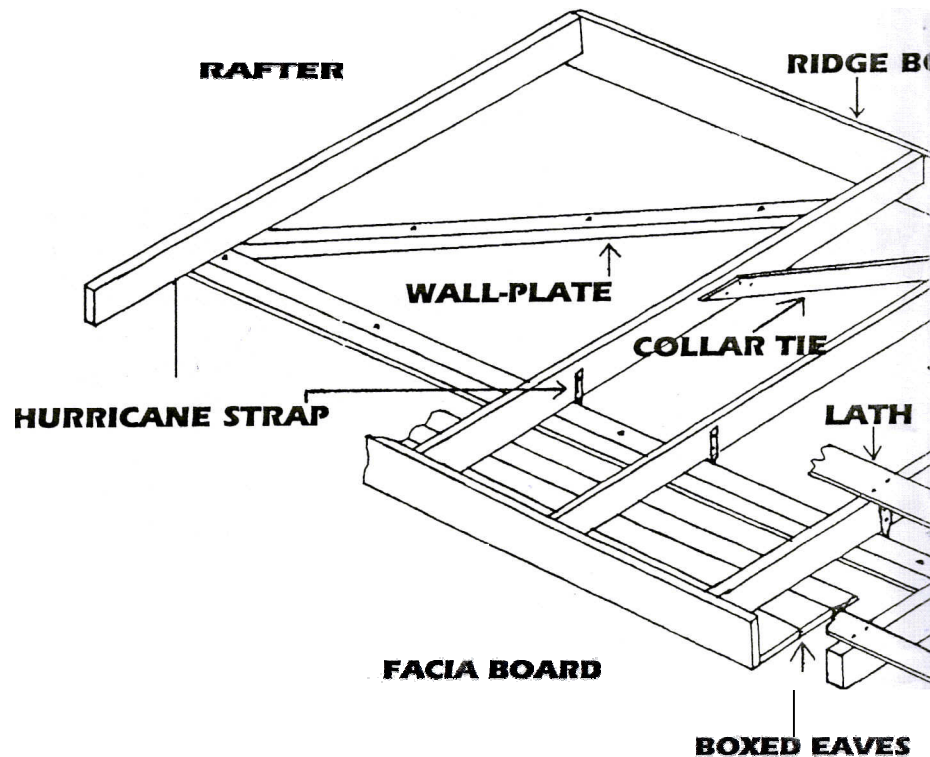

### LATHS:

Check that the spacing is a maximum 2"x 6". Use 1"x 4" treated lath with two 2½" or 3" nails each rafter. Strap or wire down lath where less nails are suspected and sheeting is not lifting.

### SHEETING:

Use 26 gauge zinc (28 or 30 gauge is too thin). Place one nail or screw, every second corrugation along the eaves and ridges; every third corrugation in the centre of the roof and every corrugation over "unboxed" gable overhang.

### EDGES:

Install fascia board along eaves. Box eaves if required. At gable end install edges strips (wood or metal).

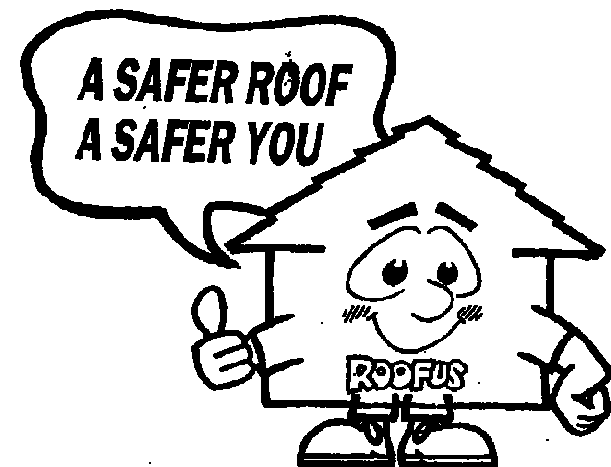

## A STEP BY STEP GUIDE

If you work on your roof in this order, additional work will be avoided.

1. Check lath spacing, and if insufficient, lift the sheeting.
2. Check for rotten timbers and replace if necessary.
3. Install hurricane straps.
4. Check wall-plate fixings and improve if necessary.
5. Fit collar ties if necessary.
6. Fit laths at correct spacing.
7. Install sheeting (check for defects) with additional nailing at the eaves and gables.
8. Fit gable end cover strips.
9. Fit fascia board and box eaves if required.

## TECHNICAL SPECIFICATIONS

Wall-plates should have: Bolts ( $\frac{1}{2}$ " dia.) at 4ft. maximum centers or if bent steel ( $\frac{1}{2}$ " or greater) at 3ft. centers.

If either is insufficient, use 1" x 1/8" steel strap over wall-plate, masonry nail into block work, or use "raw bolts" drilled and installed into belt beam.

### RAFTERS:

Install hurricane straps, one per rafter with two 3" nails or two 1  $\frac{3}{4}$ " screws each end. Install collar ties every other rafter (nailed to side of the rafter).

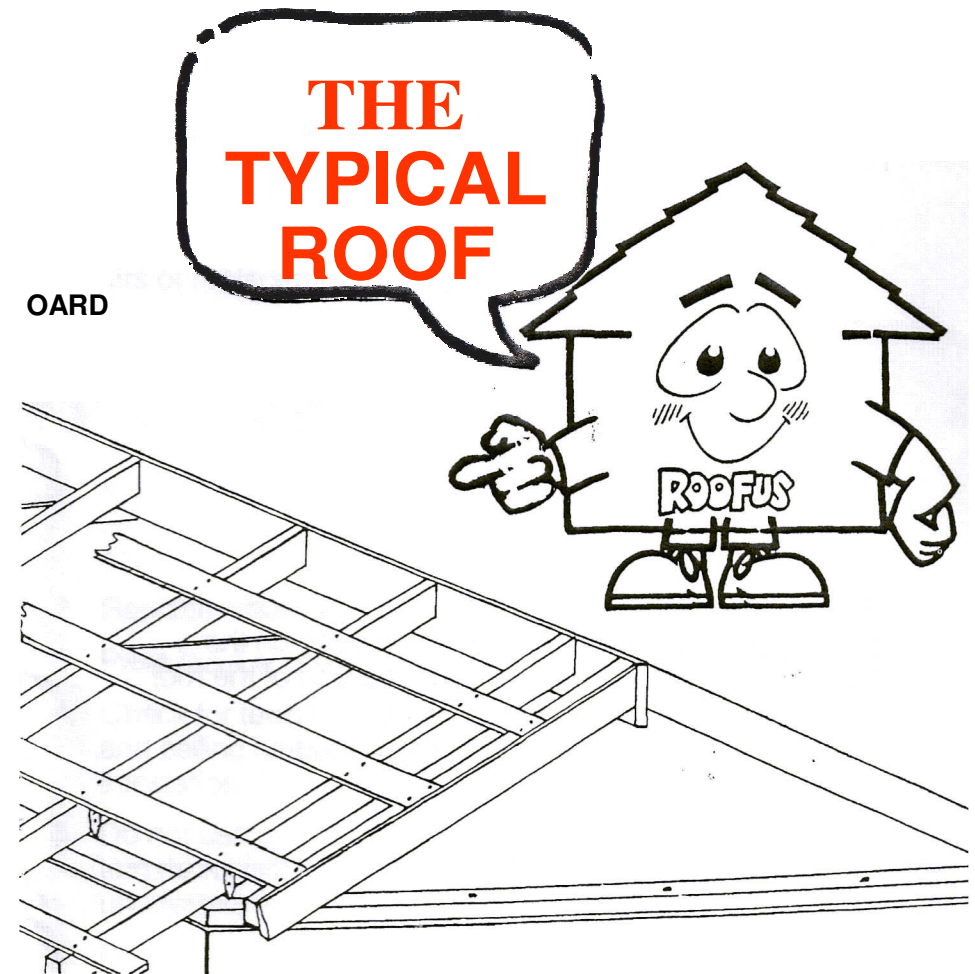

## WALLPLATE AND WALLS

The wall plate is the first connection between the walls and the rest of the roof and it forms a frame on which the other sections of the roof will sit. It must therefore be securely fastened to the rest of the building or the entire roof will lift.

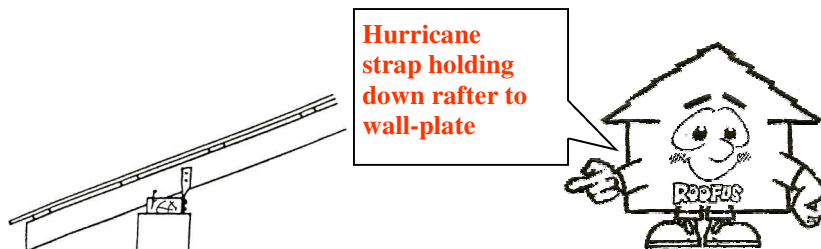

### How Damage Occurs

Builders often tie the wall-plate to the block work with bent reinforcing steel. However, depending on the thickness and spacing of the steel, the size of the roof

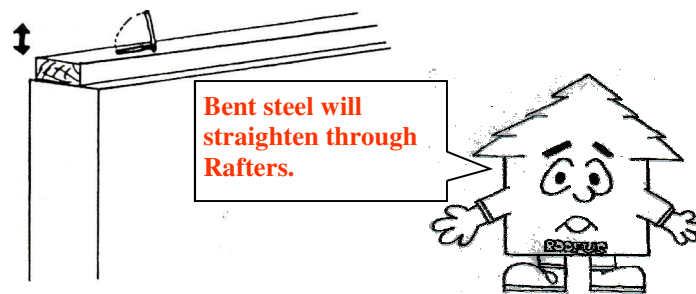

and the exposure to high winds, the steel usually straightens out during a hurricane. Once this happens, the plate will lift from the top of the building, separating the roof from the walls.

## MAINTENANCE

Many roofs fail in a hurricane because they become weak from the rusting of nails or sheeting, the rotting of roof timbers and fascia boards as a result of "unrepaired" leaks or just old age. Termites and woodworm also attack untreated or unprotected timbers thereby preventing connectors from doing their job. Maintenance of roofs keeps them strong, leak-free, and prevents costly repairs or replacement.

## A FEW TIPS

1. Inspect the roof after a heavy shower of rain and fix leaks as soon as they occur (use "flash band" on nail heads and punctures in sheeting).
2. Replace defective timbers and rusted sheeting.
3. Paint fascia and edge details to lengthen their lives.
4. Check for termite trails or dust piles from the roof and ceiling timbers. Treat thoroughly and quickly if infestation is found.
5. Do not use untreated lumber in buildings, unless it is termite resistant (e.g. cedar, mahoe). Treatment of unaffected timber will deter termite attack.
6. Galvanized sheeting tends to rust in areas subject to sea spray. Use a thick gauge aluminum sheeting in these areas, or keep your roof painted to resist the corrosive effects of salt.

A yearly inspection of the roof structure and sheeting, will ultimately save you a great deal of money.

Check that the correct gauge zinc is used. Zinc sheets should be of 26 gauge. Zinc sheeting of 28 gauge is not recommended as this is too thin and will tear easily.

## EAVES AND GABLE ENDS

Damage to the eaves and gable ends often starts because these areas are exposed.

### How Damage Occurs

The wind gets under large overhangs at the eaves and gable ends. Houses are often built with overhangs in excess of 24" with no detail at the edges to prevent the vibration and lifting of the sheets resulting from the varying pressures exerted by the gusting wind. Gable end overhangs are often used as covers for patios.

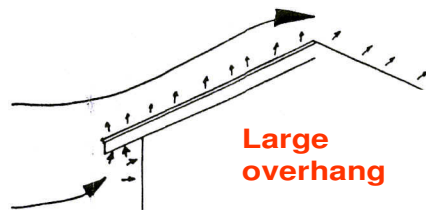

### How to Prevent the Damage

Keep overhangs as short as possible (less than 18") and use edge boards and cover strips. Consider boxing the eaves to keep the wind from pressing on the underside of the sheets.

Separate patio roofs from the main roof, or they may blow off together. Adding nails and edge covering is straightforward. Boxed eaves will help to prevent the loss of your roof.

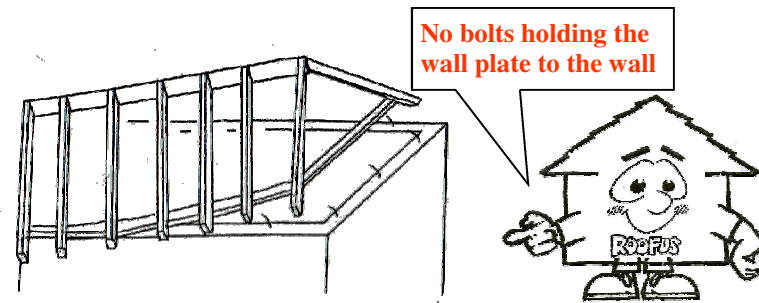

### How to Prevent Damage

For new roofs, ensure where possible, that bent steel is not used. Wall-plates should be held down with  $W' \times 8''$  long bolts with washers approximately four feet apart. The bolts should be placed at least 5" into the belt beam.

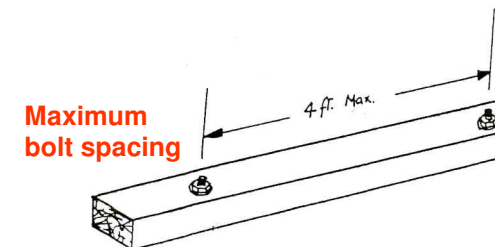

There should be at least 2" of the bolt left above the belt beam to accept the wallplate.

In some cases wall-plates are made from several short lengths of timber and these are sometimes not properly secured to the walls. Continuous lengths of timber should be used and each piece should be fastened with at least two bolts or fixings.

To strengthen an existing roof, use raw bolts drilled into the belt beam and placed four feet apart. Metal straps made from 1"x 3/16th steel sheeting can be placed over the wall-plate and fastened to the block work. If bent reinforcing steel was used previously, don't forget to check

If nails were bent over the steel to fasten it to the wallplate.

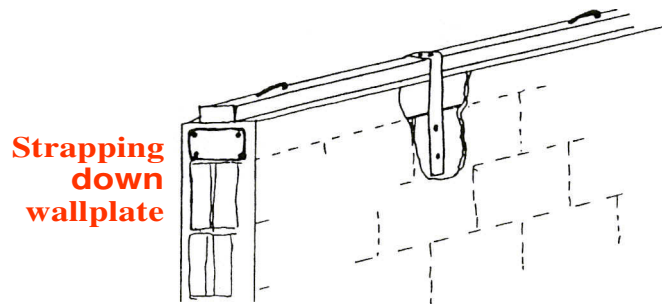

**Strapping  
down  
wallplate**

## RAFTER AND WALL-PLATE

Rafters are usually 2" by 4" deep timber (depth varies from 4" - 8") that runs from the eaves to the ridgeboard. The rafter is connected to the wallplate at the ridge. Improper installation of rafters will result in the roof falling just as easily as the other connections.

### How Damage Occurs

Rafters are normally held down to the wall-plate using diagonal (spiked) nails. These nails provide adequate support for the roof under normal conditions, but they are incapable of resisting the uplift force created by the wind.

Rafters will lift due to suction on top of the roof, and pressure under the eaves, especially if the eaves are not sealed.

Do not depend on nails only to hold the rafter to the wallplate. As the wind travels across the roof shaking it, tension is created on the joints of the rafters and this loosens the nails causing the rafters to lift.

### How Damage Occurs

Winds, travelling in excess of 65 miles per hour, causes the sheeting to vibrate pulling out the nails at the edges. The sheets then start to roll up pulling out the rest of the nails, one at a time.

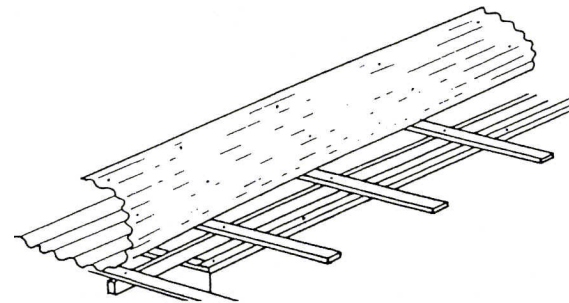

**Zinc  
sheeting  
lifting  
from rafters**

When this happens, either the nails are pulled out with the sheeting or the heads of the nails tear through the sheeting.

The use of zinc nails every third or fourth corrugation across the sheet, does not provide enough hold against the winds. Screws offer a greater degree of hold but the screw should be used at the correct spacing.

### How to Prevent Damage

Zinc should be properly nailed down particularly at the edge of the roof. Use zinc nails and fillets to hold the zinc sheeting. A recommended nailing pattern is one nail at every other corrugation along the edge, and every third corrugation in the centre of the sheet.

Use the same method when installing screws. Remember, zinc sheeting should be held down with zinc nails or screws, not wire nails.



## How to Prevent Damage

Check that the laths are placed at no more than two feet six inches apart especially if 1"x3" timber is used.

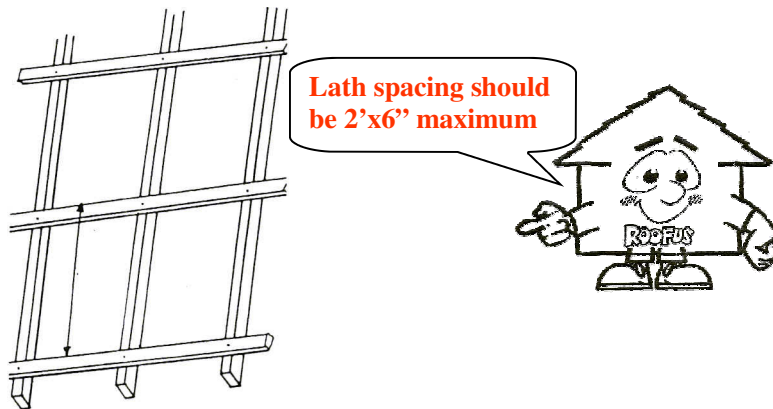

Where possible, use 1"x4" timber and make sure that they are held to the rafters with either one screw or two nail fixings.

If the laths are too widely spaced on your existing roof, more laths can be added by lifting the zinc sheeting. If you suspect that there is a weak connection, strap the lath to the rafter with wire or metal sheeting cut into strips.

## ZINC SHEETS AND LATHS

Zinc sheets protect your roof from wind and rain. However, damage to the roof often happens when the incorrect zinc gauge is used or the zinc sheets are not properly fixed to the laths.

## How to Prevent Damage

Install twisted hurricane straps where the rafters join the wall-plate. The straps should be nailed or screwed to both the wall-plate and the rafter, thereby preventing the rafters lifting off the wall-plate.



Where there are boxed eaves, access to the rafter and wall-plate will be more difficult than where the eaves are not sealed. In this situation, lift the sheeting to install the straps.

Consider raising your roof to increase the slope and reduce the pressure on the rafters. Reducing the overhang to less than 18" inches will also help to keep your roof intact.

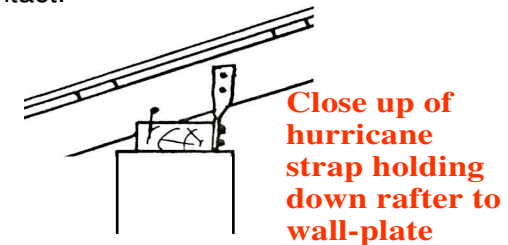

If the rafters are not connected by any straps and you cannot find straps in your local hardware stores, then old zinc sheeting, cut into strips can be used instead. Cut the sheeting into 1" wide strips and nail over the rafter and into the wall-plate. Don't forget to add hurricane straps as soon as these become available.

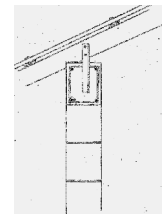

Where there is no wall plate rafter support can be accurately positioned and strapped to the belt beam formwork prior to pouring the concrete

## RAFTERS AND RIDGEBOARD

The ridgeboard is usually a 8" deep piece of board which holds both sides of the roof together at the top. Many roofs separate at the ridge when the wind passes over the roof. The risk of this happening is greater for roofs that are flat.

### How the Damage Occurs

When high winds passes over a roof, especially one that is flat, it creates an upward suction. This force is several tons in a hurricane, and will break apart the two halves of a roof at the ridgeboard.

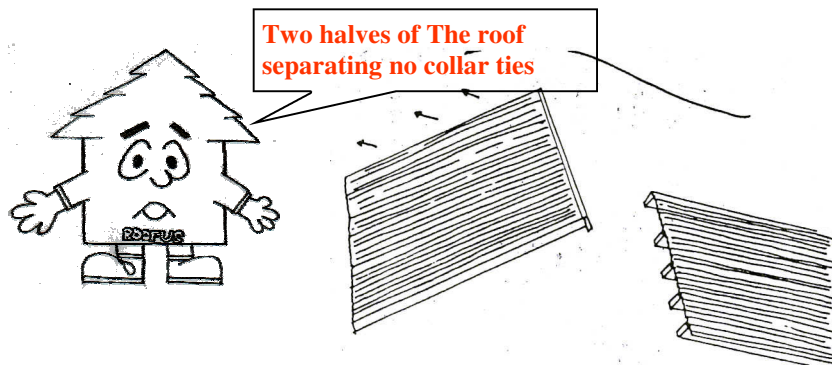

Rafters are usually nailed into the ridgeboard and this is adequate for downward load, but provides little resistance to uplift, which will pull the joints apart.

### How to Prevent Damage

A collar tie should be placed between every second or third pair of rafters. This will prevent the force of the wind pulling apart the two sides of the roof.

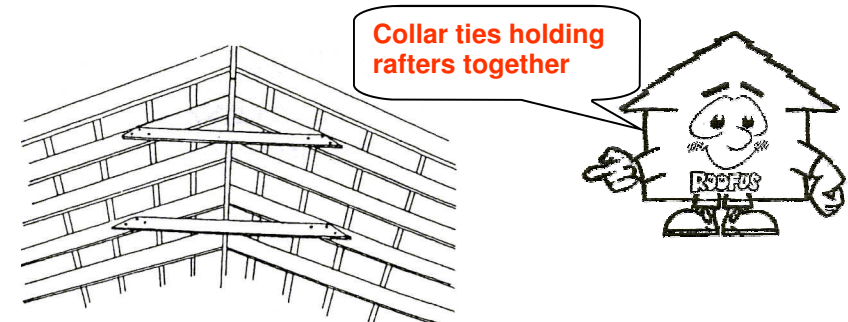

For exposed rafter situations where you don't want ties visible, a steel strap over the top of the rafter can be used instead.

## LATH TO RAFTERS

The connection of the lath to the rafter is just as important as the other connections. Many roofs have been damaged because of little attention being paid to this connection.

### How Damage Occurs

Laths are usually nailed down with one nail per rafter and in most cases; these are spaced three feet or more apart. This spacing does not allow for adequate fastening of the laths to the rafters and as the wind passes, the laths are blown off with the sheeting attached, leaving the roof exposed.

